

PROTECTOR

by



PROFILL 50 HANDBOOK



iwtm-uk.com

Email: info@IWTM-UK.com

Phone: 020 8255 2903

TABLE OF CONTENTS

DESCRIPTION AND FUNCTION	2
What is profill?	2
In line with applicable standards & guidance	2
INSTALLATION	3
Installing connections	3
Typical profill installation before pu, pu-degasser or spill unit	3
Typical profill installation after the pu	3
Safety instructions	4
DRAWING	5
OPERATING THE COMBINED METER	6
Display	6
Keys	6
Replacing the battery	6
INITIAL FILLING & REPLACING THE RESIN	7
Initial filling	7
Replacing the resin	7
PARTS	8
SERVICE JOURNAL	9

DESCRIPTION AND FUNCTION

WHAT IS PROFILL?

ProFill is a range of simple, easy to use refilling and top up units for demineralised water for heating and cooling systems. Installed in line with the systems filling device, they ensure that when used with our controlled pH resin that the filling water is supplied in accordance with the VDI 2035 standard.

The range has 4 different sizes, to accommodate your system requirements. 4L, 12.5L, 25L and 50L.

The ProFill filters lime and aggressive substances such as sulphates, nitrates and chlorides out of the fill water. The appliance uses a mixed bed ion exchanger to provide demineralised water for any system size. This method does not emit any chemical additives into the water. The appliance operates without an external power connection.

The resin beads have two types of ionexchange with the untreated water. As the untreated water passes through the ProFill, positively charged ions from the water will swap with positive hydrogen ions on the resin (cation exchange).

Similarly, negative ions in the untreated water will swap with negative hydroxyl ions on the resin beads (anion exchange). The ions will be exchanged until none is left in the water other than hydrogen and hydroxyl, making H₂O, demineralised water.

VDI 2035, SWKI Directive BT102-01 and other European standards state that water for filling heating systems should generally be demineralised for low salt

operation. Practical experience has shown that even at a low hardness level, modern appliances such as wall mounted gas boilers, heat pumps and solar thermal systems can suffer damage from limescale deposits. Compared to water that has been softened, demineralised water no longer contains any salts. Its electrical conductivity is extremely low, allowing it to act as a corrosion inhibitor.

IN LINE WITH APPLICABLE STANDARDS & GUIDANCE

It has long been clear to experts in the field that fully demineralised water is ideal for filling heating systems and that this will extend the service life of all components. Today, this technology is so user friendly and affordable that it recommends itself for practical application.

The process of full demineralisation is therefore ideal for ensuring that the water quality requirements of the following directives and standards are met:

- VDI Guideline 2035
- SWKI BT 102-01
- ÖNORM 5195-1
- DIN50930
- CIBSE Heat Network Code of Practice + Heat Network Design Guide



INSTALLATION

Protector ProFill can operate at up to 10 bar and is therefore suitable for making a permanent connection between the mains supply and the heating system.

Depending on national or local regulations, a direct connection may be subject to technical conditions which must be observed.

INSTALLING CONNECTIONS

- 2 pc 3/4" M x F Union Isolation Valve
- 2 pc 3/4" M x 1" Union Isolation Valve
- 3/4" F x F Isolation Valve
- Conductivity Meter

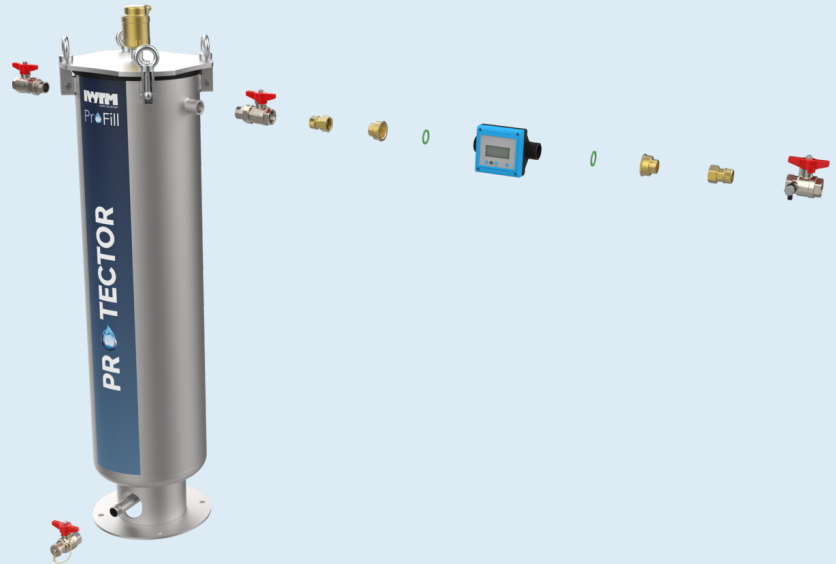

TYPICAL PROFILL INSTALLATION BEFORE PU, PU-DEGASSER OR SPILL UNIT

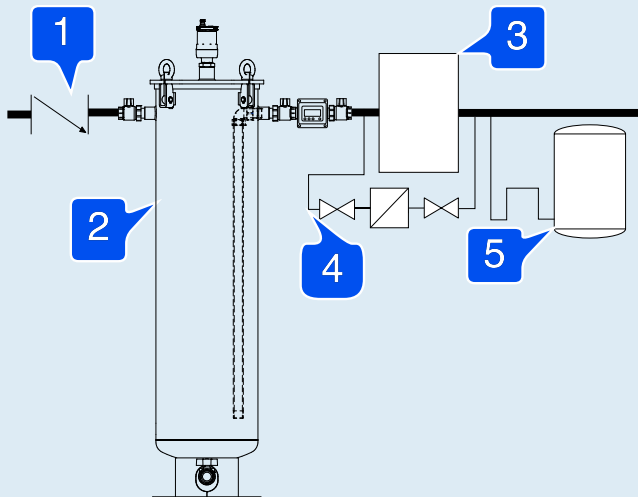

TYPICAL PROFILL INSTALLATION AFTER THE PU

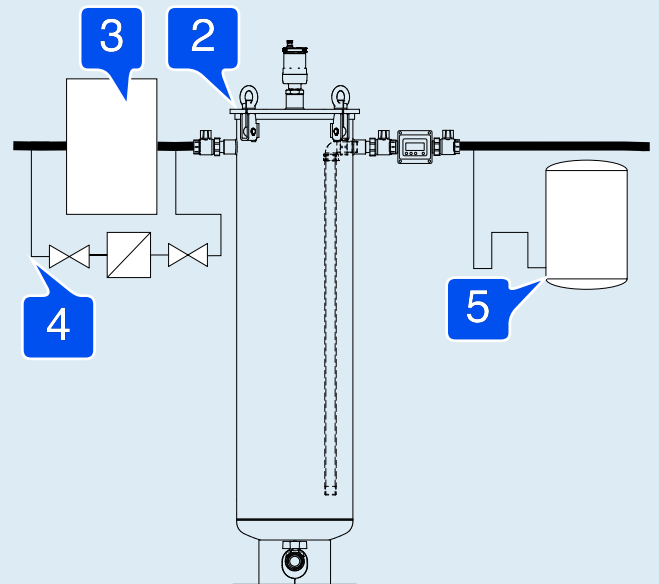

1. Back flow prevention device. 2. Profill Protector. 3. Pressurisation unit. 4. Bypass filling loop. 5. Expansion vessel.

SAFETY INSTRUCTIONS

The regulations of the water utility must be observed when connecting directly to the mains supply (e.g. system separator to DIN EN 1717).

After use, valves to the heating system and mains supply must be closed.



DRAWING

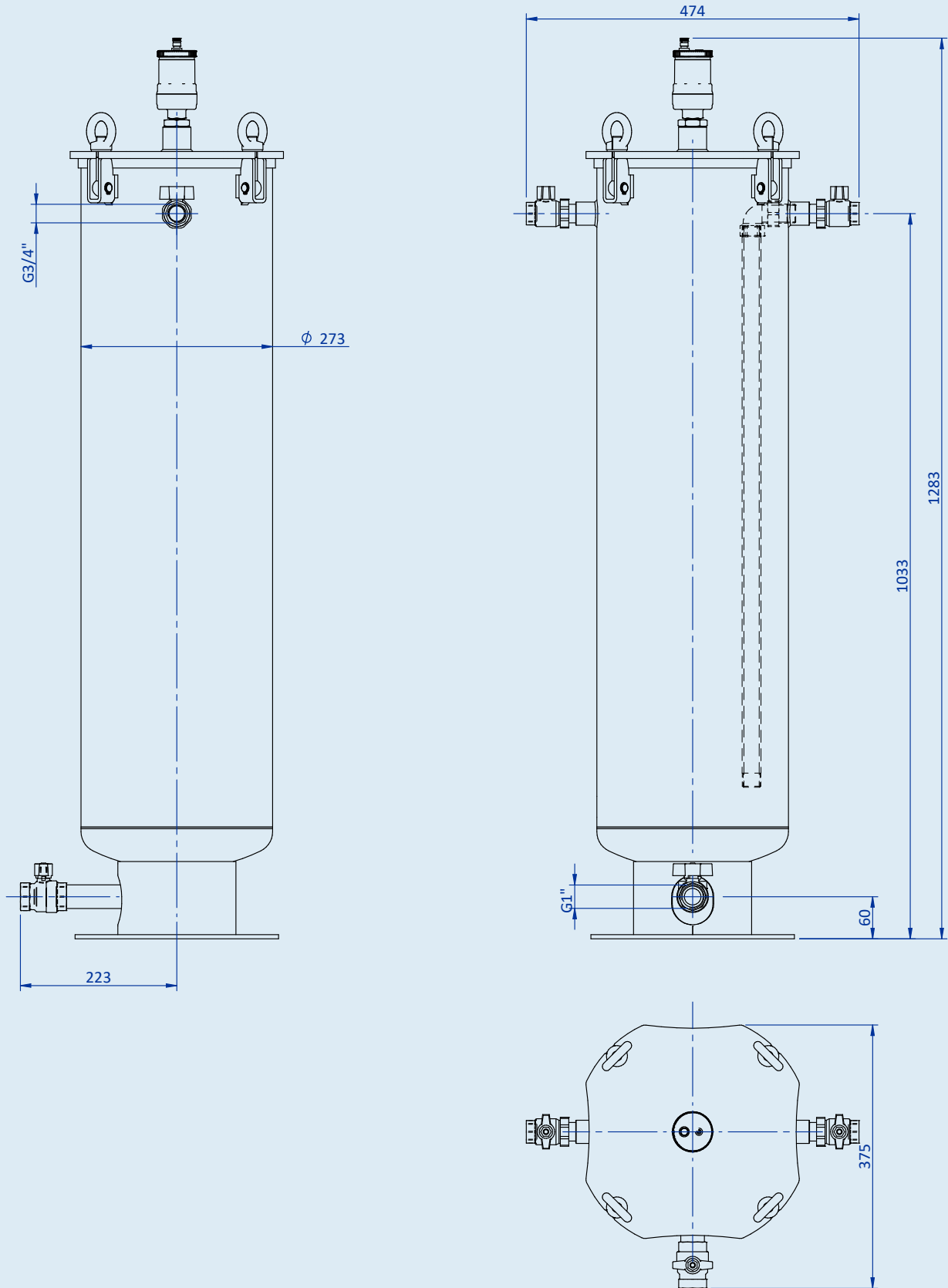

OPERATING THE COMBINED METER

The combined meter is battery-operated. It measures the flow rate in l/min, the total volume in litres and the concentration of dissolved minerals (electrical conductivity), either in micro siemens or TDS. In addition, a limit can be set for the maximum concentration of minerals tolerated in the demineralised water (ProFill outlet). The limit and flow rate total can both be reset.



DISPLAY

1. **Limit**
Recommended limit: 30 TDS/ 45/µS; above this the resin will need to be replaced.
2. **Limit warning signal**
3. **Automatic quality monitor**
4. **Total litres treated**
5. **Flow rate**

KEYS

6. **Warning limit setting**
Every time this key is pressed, the limit is increased by 10 TDS or 15 µS/cm. Pressing the key for 3 seconds resets the limit to zero. Programming the limit ensures that a warning is issued when the ion exchange resin is spent.
7. **ON / OFF**
If the ON key is pressed once, the water quality is measured for 10seconds and compared to the set limit. The measured value is shown. If it is above the limit, the LED glows red; if it is below, the LED glows green while the measurement is being taken. If required, the measurement can be re-

peated manually.

Auto mode: If the ON key is pressed twice the combined meter begins automatic monitoring. The eye symbol appears to indicate that monitoring has been enabled. In auto mode, the meter only takes measurements when water is actually passing over it. If the water draw-off is interrupted, the meter continues to show the last captured value.

While water is being drawn off, the combined meter measures the water quality every 40 litres. If the limit is exceeded in two successive measurements, the display continuously flashes red. This indicates that the ion exchange resin is spent and needs replacing. If the ON key is pressed for a third time, the meter exits auto mode.

8. TDS/µS toggle

This key can be pressed at any time to switch between TDS (total dissolved solids) and electrical conductivity. Both are units of measurement for minerals dissolved in water. Most European component manufacturers use the unit of measurement µS/cm (micro siemens).

9. Combined meter reset

Pressing the reset key for 3 seconds resets the overall total on the meter. This is recommended every time the resin is replaced, as it gives a reference point for the remaining capacity of the ion exchange resin.

REPLACING THE BATTERY

When the combined meter displays the symbol indicating a battery change is due: Carefully unscrew the front and replace the batteries. 3 x AAA.

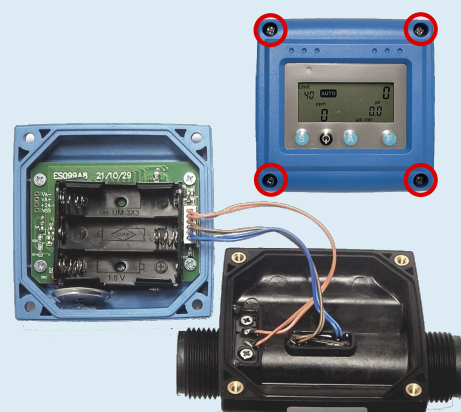

INITIAL FILLING & REPLACING THE RESIN

INITIAL FILLING

1. Undo eye bolts and remove the lid and seal.
2. Pour in the new resin. Replace the seal ensuring there is no resin on the seal.
3. Replace the lid and tighten eye bolts.
4. Reset the meter to 0.
5. Open the inlet valve and automatic air vent. When all air is dispensed open the outlet valve.
6. Check the lid is sealed and water tight.

REPLACING THE RESIN

1. Close ball valve in the outlet, connect a hose at the drain valve and route into the supplied collection sack; flush out the resin at mains pressure. Close the inlet valve and drain water, and close drain valve.
2. Continue by following the steps from 'Initial Filling'



PARTS

PRODUCT CODE	DESCRIPTION
--------------	-------------

PROTECTOR

by



IWTM was established in 1992 and has over 30 years of experience in water treatment of technical systems ranging from small single-family homes to nuclear power plants, with a focus on maritime and land-based heating and cooling systems.

DNV issued the world's first certificate for environmentally friendly water treatment "clean machinery and components" in 2003. IWTM is still the only company in the world with this type of certificate.

IWTM Protector is our latest, most innovative product and is built with the future in mind and can be adapted to SDsystems.

IWTM UK Ltd

Sutton Business Centre Restmor Way

Email: info@IWTM-UK.com

Phone: 020 8255 2903

iwtm-uk.com