

PROTECTOR

by



PROTECTOR P70 SKID HANDBOOK



iwtm-uk.com

Email: info@IWTM-UK.com

Phone: 020 8255 2903

TABLE OF CONTENTS

DESCRIPTION AND FUNCTION	2
What is protector p70?	2
Next generation water treatment	2
Particle filtration	2
Neodymium magnets	3
Sacrificial anodes	3
INSTALLATION	4
Installation	4
Startup	4
Connections	5
Coupling set	5
Startup	6
When reading the flowmeter	6
TECHNICAL DATA	7
Head loss	7
Drawing	8
MAINTENANCE AND REPAIR	9
Drainage	9
Indicator	9
SERVICE	11
Magnesium anodes	11
Particle filter	11
Procedure	12
DIGITALIZE PROTECTOR	13
Protector digital sa	13
Connectivity	13
Features	13
Security	13
PARTS	14
SERVICE JOURNAL	15

DESCRIPTION AND FUNCTION

WHAT IS PROTECTOR P70?

Protector P70 is a unique water treatment unit for closed heating and cooling systems with water and water-glycol as energy carriers.

The Protector has a “hybrid” function by purifying the water, binding oxygen, and increasing the pH value.

When the pH value is high, between 8 and 10, and there is no excess oxygen, the system will have optimal operating conditions.

NEXT GENERATION WATER TREATMENT

Most existing water treatment systems control one parameter, and therefore require multiple components for comprehensive water treatment.

With the new Protector technology, chemical treatment, filters, and magnetite traps will be replaced. This provides optimal water quality according to VDI 2035 (for hot water) and VDI 6044 (for cooling). This is a European standard.

VDI 2036 and 6044 are used by most manufacturers of equipment for heating and cooling systems as standards for water quality.

- The Protector is an “all-in-one solution”.
- It regulates pH, conductivity, and oxygen.
- It prevents bacterial growth.
- It keeps pipes, exchangers, and surfaces clean and free from deposits.
- It maintains the system’s maximum efficiency.
- There are no electrical connections.
- It can optionally be connected to an SD system.

PARTICLE FILTRATION

The Protector P70 comes standard with a stainless steel 40-micron particle filter.

The filter has a large surface area, ensuring long operation before it needs to be cleaned.

A bag filter as fine as 1 micron can also be used.



NEODYMIUM MAGNETS

The Protector has a magnet with a handle positioned in its own sensor pocket (i.e., not in physical contact with the system water).

Magnetic particles are captured on the sensor pocket. During draining, the magnets are lifted, allowing the magnetite sludge to be drained out.

SACRIFICIAL ANODES

The magnesium anodes provide anodic water treatment by dissolving into the water when oxygen is consumed. This increases the pH level while simultaneously depleting oxygen in the water.

Anode consumption adjusts to the water quality and is typically highest at startup, decreasing over time. The anodes should be cleaned or, if necessary, replaced once a year.



INSTALLATION



- A - Inlet
- B - Pump
- C - Ball valve
- D - Start panel
- E - Protector
- F - Air vent
- G - Ball valve
- H - Water meter
- I - Regulating valve
- J - Drain line
- K - Drain valve
- L - Skid frame

INSTALLATION

The protector skid should be installed as low in the system as possible, preferably on the return line. Any refill unit can be installed in the upper chamber (which is plugged). It should be placed near the drain.

STARTUP

1. Close outlet (G)
2. Open the pump inlet (A) and pump outlet (C). Make sure that the air pot / vent F is open and that air is coming out.
3. Now the tank should be filled with water and then the display instrument (in the middle of the black panel) will react, as well as the pressure switches / gauges will eventually show the system pressure.
4. When all the air is out (the gauges are still and no sound from the vent) you can open the outlet valve G.
5. Start the pump, and the water meter should now start revolutions. (clock to the left 1 round = 1 liter, next to the left 1 round = 10 liters, then 1 round = 100 liters and last 1 round = 1000 liters) use a clock and set the valve (I) to the desired amount.
6. Recommended water quantity 10l/min

INSTALLATION ON STEAM AND COOLING TOWER.

When installing on "open systems," such as hot wells in steam plants or cooling towers, a prefabricated solution with a pump and control cabinet is supplied. This solution can also be used, for example, when mounting on the return flow of a single pipe system.

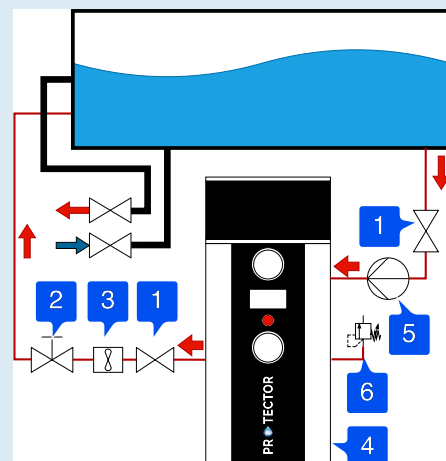

CONNECTIONS

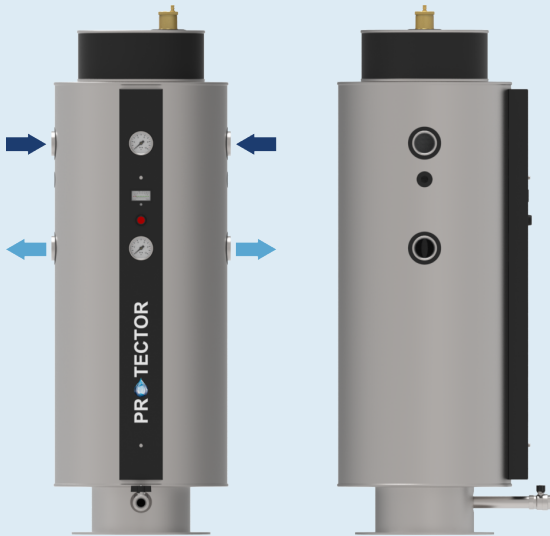

- In from the right or left. The inlet is the upper chamber. The unused inlet can be plugged or used for refilling.
- Out from the right or left side. The unused side should be plugged.

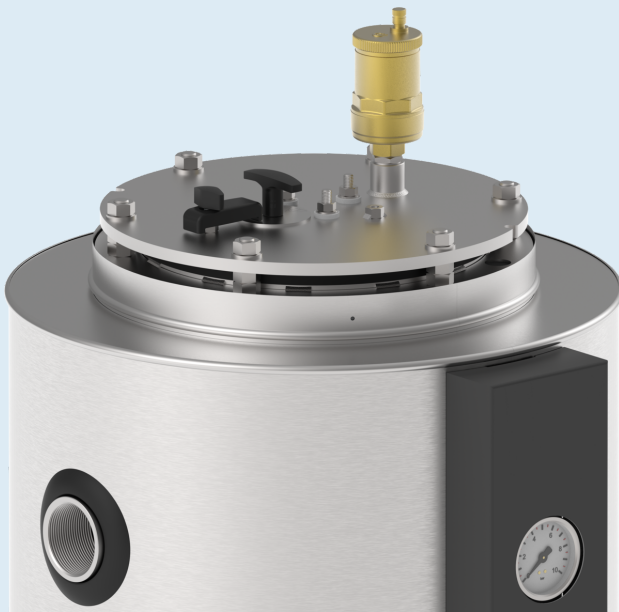

The flange is under the "top hat." Here you can also see the insulation screws to which the anodes are attached, as well as the handle for the magnet.

COUPLING SET



- 2 pcs. 1 1/2" ball valves (inlet/outlet)
- 2 pcs. 1 1/2" plugs (plugs for unused inlet/outlet)
- 1 pc. Water meter
- 1 pc. 1 1/2" throttle valve
- 1 pc. 1/2" air vent pot
- 1 pc. 1" drain valve
- 1 pc. Sampling point for water test

Ensure adequate working height for anode replacement over the Protector.

Minimum space above for Protector P70 is 100 cm

STARTUP

- Close the outlet.
- Open the inlet.
- Remove the cover and unscrew the cap on the air vent pot.
- Air should now come out of the air vent pot.
- The gauge should start moving/show a reading.
- Once all air is out of the Protector, open the outlet.
- The indicators on the water meter should now start moving.

Note: Check that they are moving in the correct direction (i.e., that the water flows the right way).

WHEN READING THE FLOWMETER

- Dial farthest to the left: 1 liter = 1 revolution
- Dial second from the left: 1 revolution = 10 liters
- Dial second from the right: 1 revolution = 100 liters
- Dial farthest to the right: 1 revolution = 1000 liters

When making adjustments, wait 1 minute and read the liters per minute.

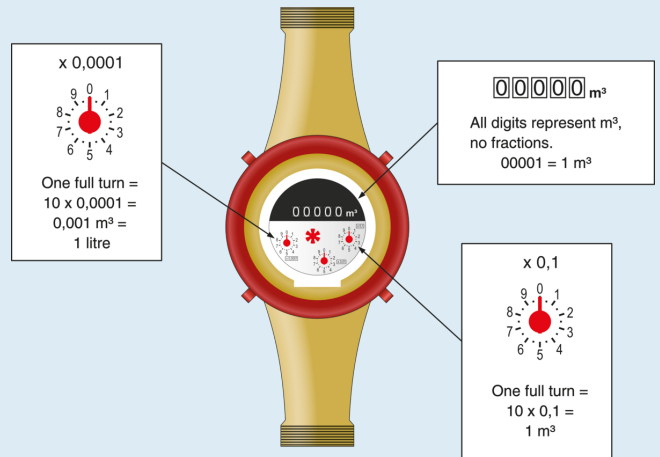

TECHNICAL DATA

TECHNICAL SPECIFICATIONS

Wet weight, kg:	198
Min working space above, cm:	100
Transport weight, kg:	157
Max system volume - heating, m ³ :	70
Dry weight, kg:	88
Connection:	2" F BSSP
Design code:	PED 2014/68/EU
Tank volume, L:	130
Medium temperature, °C:	95
Design pressure, bar:	PN10
Max water flow (system flushing), l/min:	160
Water flow, l/min:	0-80
Max system volume - cooling, m ³ :	60

MATERIALS

Surface treatment:	High gloss polished
Magnet:	Neodymium
Anodes:	Magnesium
Manometer:	Stainless AISI 304
Insulation/Cladding:	Armaflex/stainless
Gasket:	EPDM
Filter element:	Stainless AISI 316
Filter housing:	Stainless AISI 304

Note: Other pressures and temperatures are available upon request.

HEAD LOSS

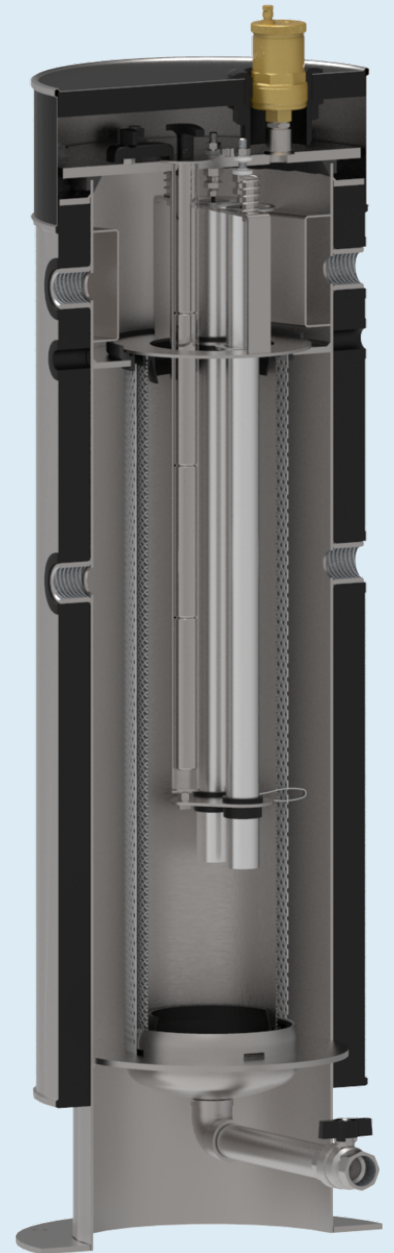
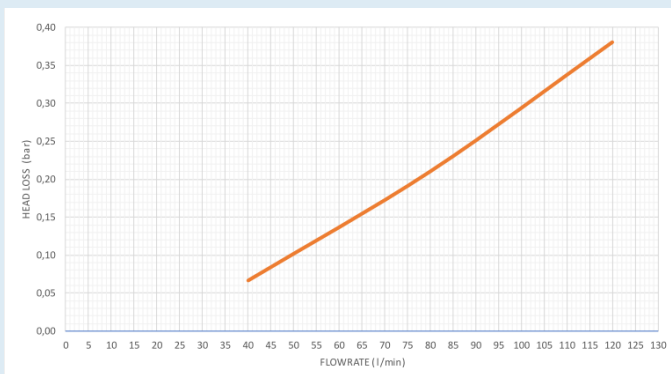

DRAWING

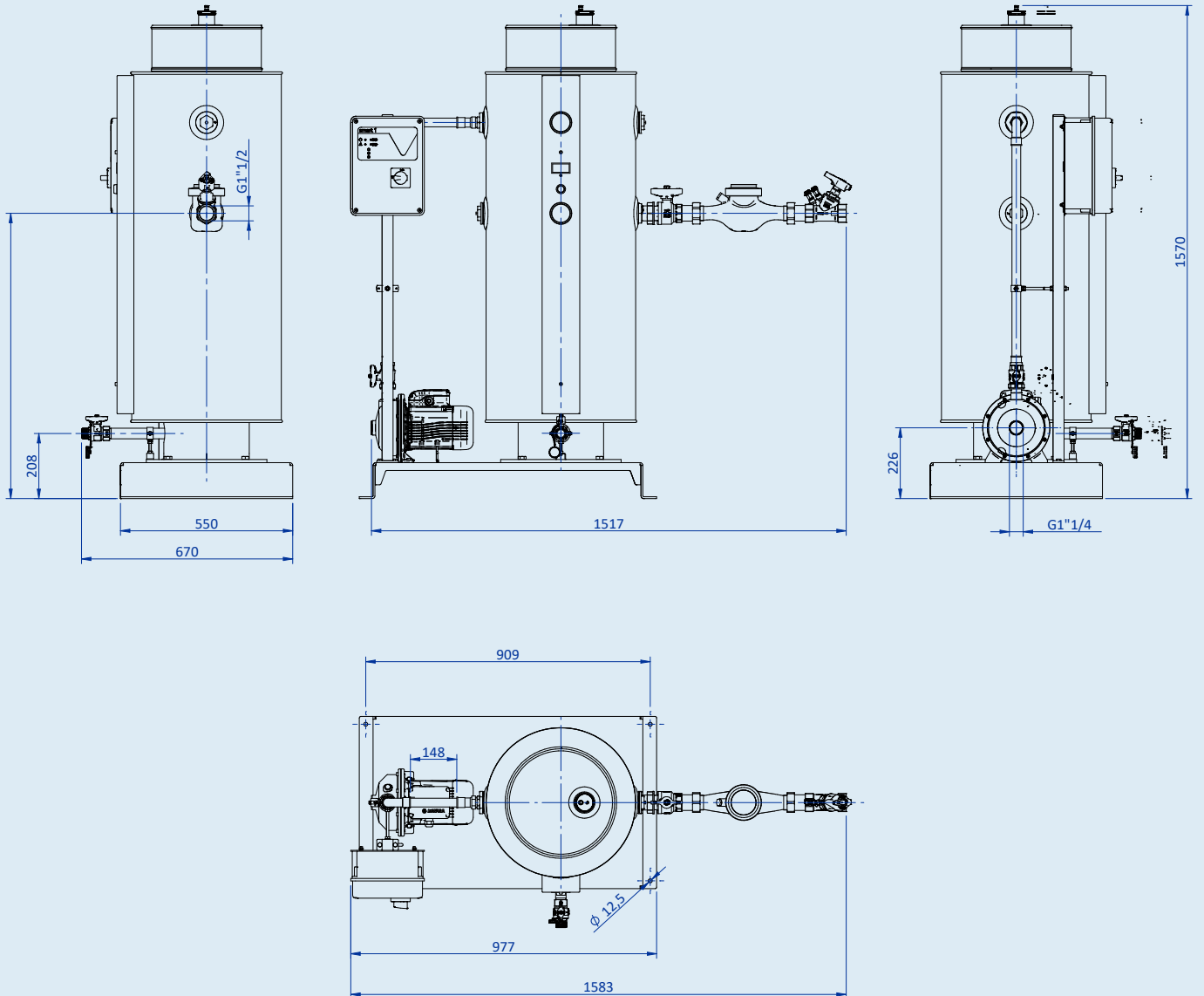

MAINTENANCE AND REPAIR

DRAINAGE

Protector must be drained regularly, most commonly at startup and then at longer intervals, depending on water quality. The usual service frequency is once a year. When there is a lot of sludge, it must be drained often. When the water becomes clean, the intervals are extended. The result is clean, clear water without sludge and particles.



Protector P70 has a magnet with a handle. This is located under the "hat", on the flange of the Protector itself.

- Close off the entrance to the Protector.
- Lift up the magnet(s).
- Open the drainage valve at the bottom of the Protector.
- When the water has become cleaner, the valve can be closed.
- Put the magnet back.
- Open the entrance.



INDICATOR

The display instrument shows the galvanic current that goes from the anode to the cathode (anode consumption).

The button on the display instrument is only used to break the current and reset the instrument.

The protector is self-regulating. If there is a lot of pollution and oxygen present in the water, it will give a high reading. Similarly, the reading will be low when the water quality is good.

After the system has been running for a while, it is normal for the reading on the instrument to be almost 0 (4-15 mA).

MEASURES

Drain the tank, and check the water. The protector should be opened once a year.

READINGS BETWEEN 5 AND 100 PERCENT

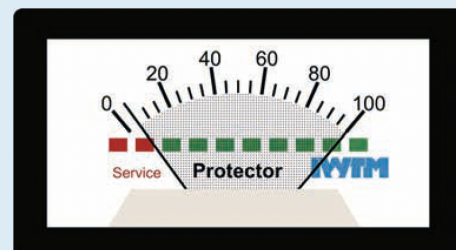

This is typical reading during start-up. Over time, the deviation will decrease.

CONTINUOUS INCREASE TO 100 PERCENT

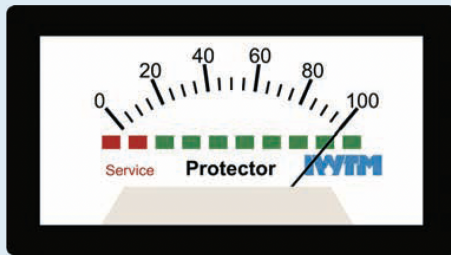

If the deviation is 100 percent over a longer period (over one season), an analysis of the water should be conducted. Possible causes are that the Protector is too small, or that a lot of new water is added. Previous use of chemicals and inhibitors can result in such deviations.

LITTLE OR NO RESPONSE ON THE DISPLAY INSTRUMENT

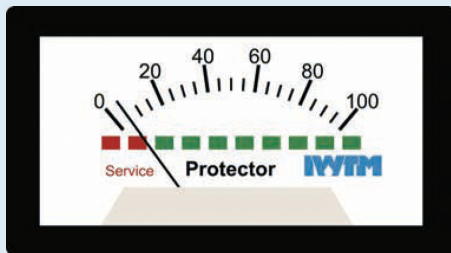

Generally, we recommend opening and checking the anode/filter once a year.

If the reading is low, it could be that

1. the water is neutralized
2. the anode is covered with deposits (chemicals)
3. there is no electrical contact between the entry and the flange (check insulation/entry to the anode).

THE DISPLAY INSTRUMENT, AS MENTIONED, PROVIDES AN INDICATION OF THE ANODE CONSUMPTION. THE CONSUMPTION IS A RESULT OF THE WATER QUALITY.

Bad water causes high anode consumption.

Clean water results in low anode consumption.

Open and check the anode once a year.

THE INDICATOR REACHES RED LEVEL WITHIN A FEW DAYS.

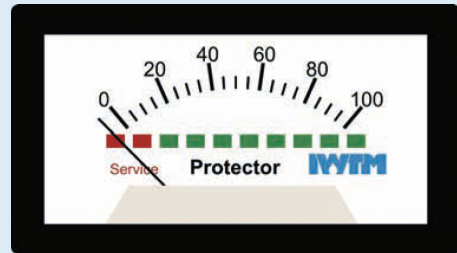

The anode can be insulated with coating from previous chemicals. Open and clean the anode (scrape clean with knife).

If the instrument, on the other hand, presses down towards "red" and bounces up when pressing the reset button, they are incorrectly connected +/-.

Action: Change the wires on the top and the instrument should display a normal reading (+/-) if they were swapped incorrectly.

THE DISPLAY INSTRUMENT SHOWS CONTINUOUS MOVEMENT OVER A LONG PERIOD.

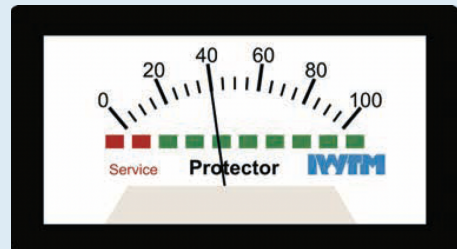

The display instrument may be damaged.

Action: Press the red button to cut off the anode current. The instrument should now go to 0. If it remains still, it is damaged.

Over time, the Protector will neutralize the water, by increasing the pH value while oxygen is consumed." "Neutral water reduces anode consumption, and the indicator will typically have a reading of 4-15 mA when it is refilled with fresh oxygen-rich water.

When refilled with fresh oxygen-rich water, the anode consumption will increase and the indicator will show a reading.

SERVICE

We recommend annual service for the Protector, but the frequency also depends on the water quality.

Take a water sample when starting the Protector.

Parameters for the water sample: pH, conductivity, iron and copper.

MAGNESIUM ANODES

The Protector can be delivered with two types of anodes, with or without mesh. Anodes with mesh cannot be cleaned and must be replaced during service. Anodes without mesh can be scraped clean with a knife or similar and used further.

TOOLS

Insulation screw: 13 mm wrench

Insulation side, "water side": 17 mm wrench.

Anode screw: 10 mm wrench

Flange: 19 mm wrench/pipe

The isolation screw has a Teflon gasket on each side. These Teflon gaskets have two functions:

- prevent water leakage
- prevent electrical breakdown

Be careful not to tighten too hard. This is to avoid squeezing out the Teflon gaskets.

It is recommended to use a voltmeter to check that there is no electrical contact between the flange and the insulation screw (remove the wires when checking this).

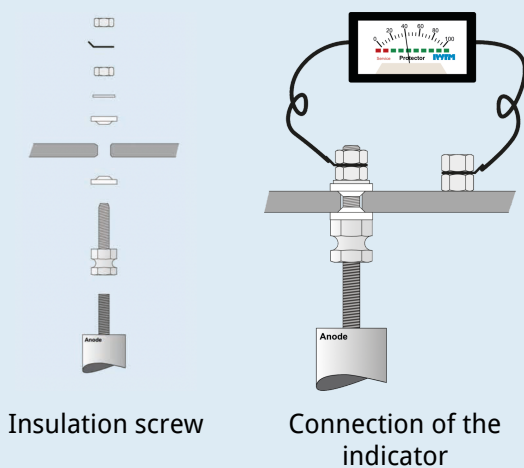

PARTICLE FILTER

Inside the Protector there is a vertical stainless particle filter.

- The filter is loose and can be removed by hand.
- Lift out the filter (turn and lift.)
- Now you will see the external filter (this is for support of any bag filter).
- Rinse and clean inside.
- Clean filters provide faster operation and longer service intervals.

When it is properly installed, make sure that the seal between the filter and the anode chamber is tight, so that the water does not go outside the filter.

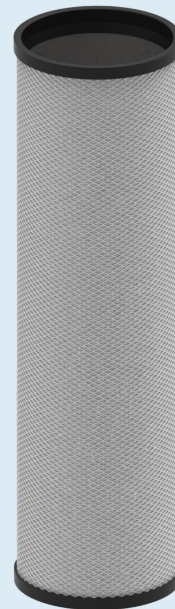

AISI 316 with either 110 or 40 microns.

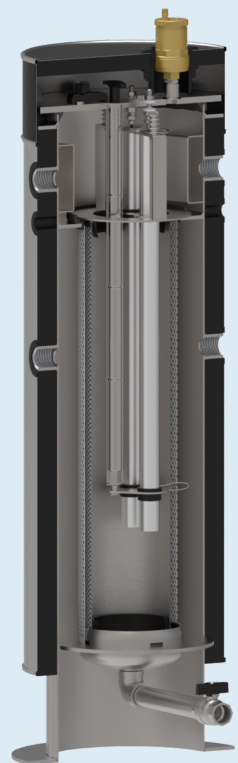

Cross-section showing upper chamber with magnets, before descending into the actual particle filter and anode chamber.

PROCEDURE

1. Close inlet and outlet.
2. Open drainage valve.
3. Remove the air valve to prevent vacuum and allow faster drainage.
4. Remove the top cover and lift out the magnet.
5. Loosen the flange carefully lift it. The anodes are located on the underside of the flange.
6. Inspect the anodes and clean them if necessary. Replace the anodes if they are significantly reduced and have a rough surface. The anodes are screwed firmly into the insulation screw. This must be held in place and not twisted around.
7. Remove the retaining clip for the filter.
8. Lift out the filter, rinse it and clean it.
9. Clean the inside of the tank with a hose or pressure washer.
10. After everything is done, reattach the filter, anodes, and flange.
11. Fill the Protector from the inlet.
12. When there is no more air coming out of the air vent, you can open the return valve. This should start the circulation.
13. Check the water meter and record the reading in a log.



Step 2

Step 3



Step 4

Step 5



Step 7

Step 8

DIGITALIZE PROTECTOR



PROTECTOR DIGITAL SA

In our digitalized world, it's important to have the option to control everything remotely, and water treatment equipment is no exception. Therefore, we have created an add-on for Protector to digitalize it.

CONNECTIVITY

- Ethernet
- WiFi
- LTE
- RS485
- 4-20mA

FEATURES

- Digital sensors for flow, conductivity, temperature, pressure, and anode current, with optional oxygen and pH sensors.
- Connection to a BMS: Modbus/RTU, Modbus/TCP, BACnet, BasTech, 4-20mA.
- Internal web-server for monitoring within a local network.
- Online monitoring, remote control, alarms and notifications via our cloud service.
- Automatic pressure control and refilling.
- Leak detection.

SECURITY

Protector Digital uses secure technologies to communicate with the cloud and enable remote control over the Internet:

- The operating system is embedded in the processor, is protected from reading, and cannot be hacked.
- All traffic is encrypted using SSL
- Each device has its own security token
- Each device has its own authentication credentials on IoT server
- The cloud API is protected by an authentication system

PARTS

PRODUCT CODE	DESCRIPTION
PROTECTOR	
101459	PROTECTOR P70 MAXI 1 1/2" F
SPARE PARTS	
101602	AIRVENT P10 - P70
101565	ANODE SET P70
100125	REGULATING VALVE 1 1/2"
101801	FLOWMETER 1 1/2"
100078	INDICATOR 0-100mA
100081	INDICATOR TEST BUTTON
BAGFILTERS	
101142	BAG FELT PES SIZE 02 Ø 178 x L 813 mm 200 µm
101143	BAG FELT PES SIZE 02 Ø 178 x L 813 mm 50 µm
101144	BAG FELT PES SIZE 02 Ø 178 x L 813 mm 25 µm
101145	BAG FELT PES SIZE 02 Ø 178 x L 813 mm 10 µm
101146	BAG FELT PES SIZE 02 Ø 178 x L 813 mm 5 µm
101147	BAG FELT PES SIZE 02 Ø 178 x L 813 mm 1 µm
101449	BAG FELT PES SIZE 02 Ø 178 x L 813 mm 100 µm
GASKETS	
101159	VESSEL GASKET Ø273 (EPDM)
101609	GASKET BAG HOLDER (EPDM)
101860	GASKET FOR FILTERKIT PRBG P70 (2PCS)
SS STRAINERS	
101555	2LAY INOX FILTERKIT SIZE 30, 40µm
101556	2LAY INOX FILTERKIT SIZE 30, 110µm
SPARE PARTS	
101606	TOP COVER P40- P70
111267	PRESSURE GAUGE
101131	MAGNET P40-70-200

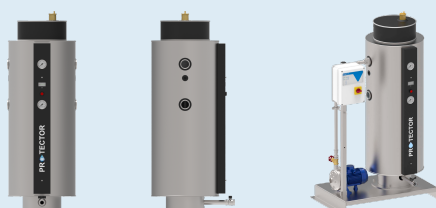

PROTECTOR

by



IWTM was established in 1992 and has over 30 years of experience in water treatment of technical systems ranging from small single-family homes to nuclear power plants, with a focus on maritime and land-based heating and cooling systems.

DNV issued the world's first certificate for environmentally friendly water treatment "clean machinery and components" in 2003. IWTM is still the only company in the world with this type of certificate.

IWTM Protector is our latest, most innovative product and is built with the future in mind and can be adapted to SDsystems.

IWTM UK Ltd

Sutton Business Centre Restmor Way

Email: info@IWTM-UK.com

Phone: 020 8255 2903

iwtm-uk.com